

# PIN-BUSH TYPE FLEXIBLE BRAKE DRUM COUPLING

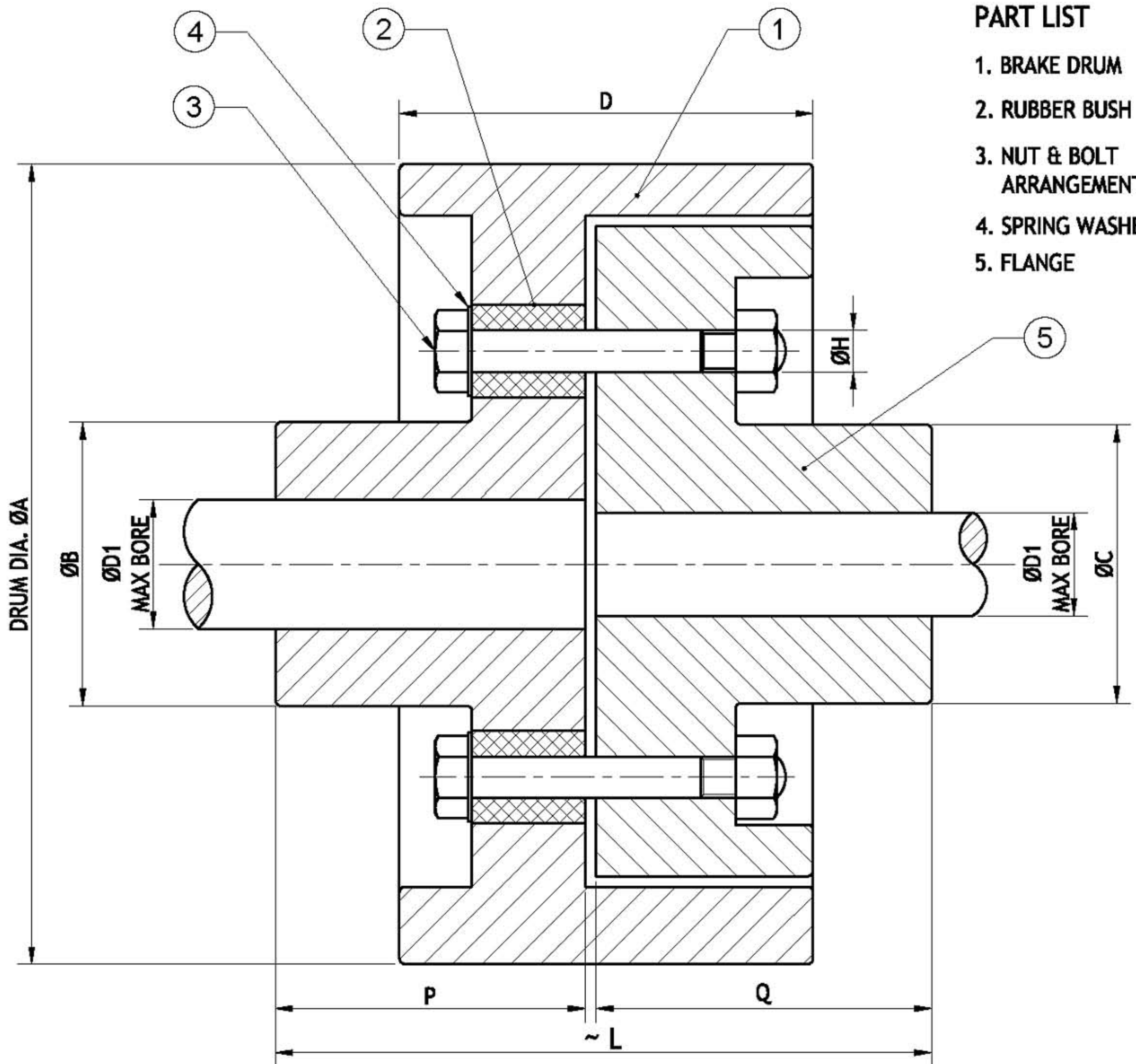

## PART LIST

1. BRAKE DRUM
2. RUBBER BUSH
3. NUT & BOLT ARRANGEMENT
4. SPRING WASHER
5. FLANGE

NOTE : ALL DIMENSIONS ARE IN MM. ALTERATIONS RESERVED.

[www.powermechengineering.in](http://www.powermechengineering.in)

DRUM DIA ØA	ØB	ØC	D	P	Q	~ L	Ø D1 MAX	Ø D2 MAX	ØH	WT (KG)	NO.OF BOLTS	PILOT BORE
100	55	54	80	43	45	88	20	20	8	4	4	12
150	70	69	77	78	53	131	30	30	10	10	6	16
200	83	82	102	88	87	175	55	55	17	18	6	19
250	105	102	130	107	86	193	55	55	17	28	6	25
300	128	127	152	114	96	210	75	75	20	61	6	25
400	150	150	180	140	108	248	100	100	20	130	8	32

